

Name: _____

Trigonometry

Date:

Time: 270

Total marks available: 270

Total marks achieved: _____

Mathvault.io

Questions

Q1.

In this question you must show all stages of your working.

Solutions relying on calculator technology are not acceptable.

Given that the first three terms of a geometric series are

$$12\cos\theta \quad 5 + 2\sin\theta \quad \text{and} \quad 6\tan\theta$$

(a) show that

$$4\sin^2\theta - 52\sin\theta + 25 = 0$$

(3)

Given that θ is an obtuse angle measured in radians,

(b) solve the equation in part (a) to find the exact value of θ

(2)

(c) show that the sum to infinity of the series can be expressed in the form

$$k(1 - \sqrt{3})$$

where k is a constant to be found.

(5)

(Total for question = 10 marks)

(Q15 9MA0/02, June 2022)

Q2.

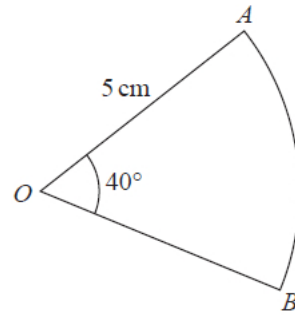

Figure 1

Figure 1 shows a sector AOB of a circle with centre O , radius 5 cm and angle $AOB = 40^\circ$

The attempt of a student to find the area of the sector is shown below.

$$\begin{aligned}\text{Area of sector} &= \frac{1}{2}r^2\theta \\ &= \frac{1}{2} \times 5^2 \times 40 \\ &= 500 \text{ cm}^2\end{aligned}$$

(a) Explain the error made by this student.

(1)

(b) Write out a correct solution.

(2)

(Total for question = 3 marks)

(Q03 9MA0/02, June 2019)

Q3.

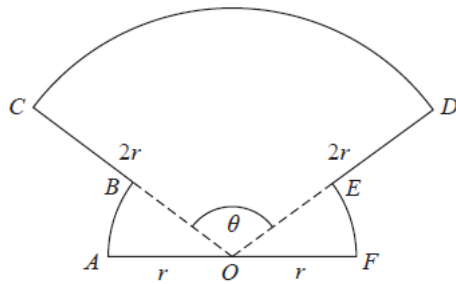

Figure 1

The shape $OABCDEFO$ shown in Figure 1 is a design for a logo.

In the design

- OAB is a sector of a circle centre O and radius r
- sector OFE is congruent to sector OAB
- ODC is a sector of a circle centre O and radius $2r$
- AOF is a straight line

Given that the size of angle COD is θ radians,

(a) write down, in terms of θ , the size of angle AOB

(1)

(b) Show that the area of the logo is

$$\frac{1}{2}r^2(3\theta + \pi)$$

(2)

(c) Find the perimeter of the logo, giving your answer in simplest form in terms of r , θ and π .

(2)

(Total for question = 5 marks)

(Q06 9MA0/02, Oct 2021)

Q4.

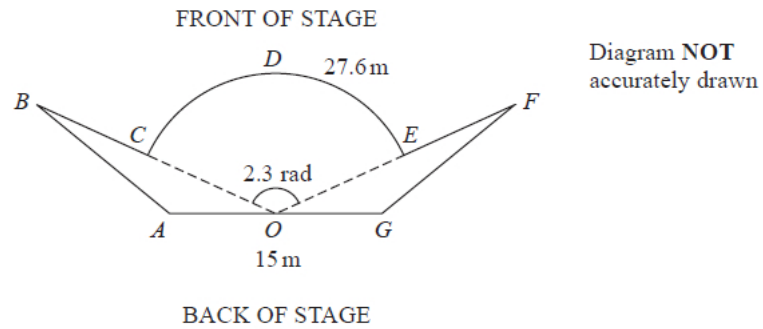

Figure 1

Figure 1 shows the plan view of a stage.

The plan view shows two congruent triangles ABO and GFO joined to a sector $OCDEO$ of a circle, centre O , where

- angle $COE = 2.3$ radians
- arc length $CDE = 27.6$ m
- AOG is a straight line of length 15 m

(a) Show that $OC = 12$ m.

(2)

(b) Show that the size of angle AOB is 0.421 radians correct to 3 decimal places.

(2)

Given that the total length of the front of the stage, $BCDEF$, is 35 m,

(c) find the total area of the stage, giving your answer to the nearest square metre.

(6)

(Total for question = 10 marks)

(Q08 9MA0/01, June 2023)

Q5.

The curve C has parametric equations

$$x = 2 \cos t, \quad y = \sqrt{3} \cos 2t, \quad 0 \leq t \leq \pi$$

- (a) Find an expression for $\frac{dy}{dx}$ in terms of t .

(2)

The point P lies on C where $t = \frac{2\pi}{3}$

The line l is the normal to C at P .

- (b) Show that an equation for l is

$$2x - 2\sqrt{3}y - 1 = 0$$

(5)

The line l intersects the curve C again at the point Q .

(c) Find the exact coordinates of Q .

You must show clearly how you obtained your answers.

(6)

(Total for question = 13 marks)

(Q13 9MA0/01, Specimen papers)

Q6.

Given that θ is small and is measured in radians, use the small angle approximations to find an approximate value of

$$\frac{1 - \cos 4\theta}{2\theta \sin 3\theta}$$

(3)

(Total for question = 3 marks)

(Q01 9MA0/01, June 2018)

Q7.

(a) Prove that

$$\tan \theta + \cot \theta \equiv 2 \operatorname{cosec} 2\theta, \quad \theta \neq \frac{n\pi}{2}, n \in \mathbb{Z}$$

(4)

(b) Hence explain why the equation

$$\tan \theta + \cot \theta = 1$$

does not have any real solutions.

(1)

(Total for question = 5 marks)

(Q09 9MA0/01, Specimen papers)

Q8.

The depth of water, D metres, in a harbour on a particular day is modelled by the formula

$$D = 5 + 2 \sin(30t)^\circ \quad 0 \leq t < 24$$

where t is the number of hours after midnight.

A boat enters the harbour at 6:30 am and it takes 2 hours to load its cargo.

The boat requires the depth of water to be at least 3.8 metres before it can leave the harbour.

(a) Find the depth of the water in the harbour when the boat enters the harbour.

(1)

(b) Find, to the nearest minute, the earliest time the boat can leave the harbour.

(Solutions based entirely on graphical or numerical methods are not acceptable.)

(4)

(Total for question = 5 marks)

(Q08 9MA0/01, June 2018)

Q9.

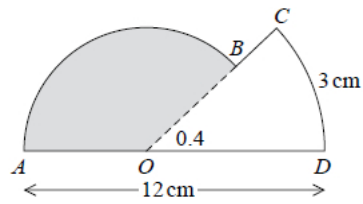

Figure 1

The shape $ABCDOA$, as shown in Figure 1, consists of a sector COD of a circle centre O joined to a sector AOB of a different circle, also centre O .

Given that arc length $CD = 3$ cm, $\angle COD = 0.4$ radians and AOD is a straight line of length 12 cm,

(a) find the length of OD ,

(2)

(b) find the area of the shaded sector AOB .

(3)

(Total for question = 5 marks)

(Q02 9MA0/01, Specimen papers)

Q10.

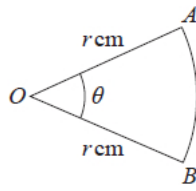

Figure 1

Figure 1 shows a sector AOB of a circle with centre O and radius r cm.

The angle AOB is θ radians.

The area of the sector AOB is 11 cm^2

Given that the perimeter of the sector is 4 times the length of the arc AB , find the exact value of r .

(4)

(Total for question = 4 marks)

(Q03 9MA0/01, June 2018)

Q11.

On a roller coaster ride, passengers travel in carriages around a track.

On the ride, carriages complete multiple circuits of the track such that

- the maximum vertical height of a carriage above the ground is 60 m
- a carriage starts a circuit at a vertical height of 2 m above the ground
- the ground is horizontal

The vertical height, H m, of a carriage above the ground, t seconds after the carriage starts the first circuit, is modelled by the equation

$$H = a - b(t - 20)^2$$

where a and b are positive constants.

(a) Find a complete equation for the model.

(3)

(b) Use the model to determine the height of the carriage above the ground when $t = 40$

(1)

In an alternative model, the vertical height, H m, of a carriage above the ground, t seconds after the carriage starts the first circuit, is given by

$$H = 29 \cos(9t + \alpha)^\circ + \beta \quad 0 \leq \alpha < 360^\circ$$

where α and β are constants.

(c) Find a complete equation for the alternative model.

(2)

Given that the carriage moves continuously for 2 minutes,

(d) give a reason why the alternative model would be more appropriate.

(1)

(Total for question = 7 marks)

Q12.

Some A level students were given the following question.

Solve, for $-90^\circ < \theta < 90^\circ$, the equation

$$\cos \theta = 2 \sin \theta$$

The attempts of two of the students are shown below.

<u>Student A</u>
$\cos \theta = 2 \sin \theta$
$\tan \theta = 2$
$\theta = 63.4^\circ$

<u>Student B</u>
$\cos \theta = 2 \sin \theta$
$\cos^2 \theta = 4 \sin^2 \theta$
$1 - \sin^2 \theta = 4 \sin^2 \theta$
$\sin^2 \theta = \frac{1}{5}$
$\sin \theta = \pm \frac{1}{\sqrt{5}}$
$\theta = \pm 26.6^\circ$

(a) Identify an error made by student A.

(1)

Student B gives $\theta = -26.6^\circ$ as one of the answers to $\cos \theta = 2 \sin \theta$.

- (b) (i) Explain why this answer is incorrect.
(ii) Explain how this incorrect answer arose.

(2)

(Total for question = 3 marks)

(Q02 9MA0/02, Specimen papers)

Q13.

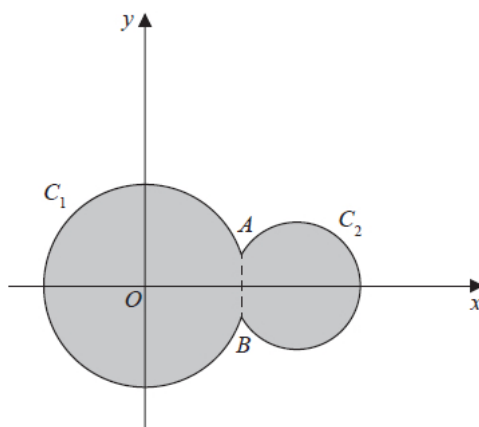

Figure 3

Circle C_1 has equation $x^2 + y^2 = 100$

Circle C_2 has equation $(x - 15)^2 + y^2 = 40$

The circles meet at points A and B as shown in Figure 3.

(a) Show that angle $AOB = 0.635$ radians to 3 significant figures, where O is the origin.

The region shown shaded in Figure 3 is bounded by C_1 and C_2

(b) Find the perimeter of the shaded region, giving your answer to one decimal place.

(4)

(Total for question = 8 marks)

(Q11 9MA0/01, Oct 2020)

Q14.

- (a) Express $10 \cos \theta - 3 \sin \theta$ in the form $R \cos (\theta + \alpha)$, where $R > 0$ and $0 < \alpha < 90^\circ$
Give the exact value of R and give the value of α , in degrees, to 2 decimal places.

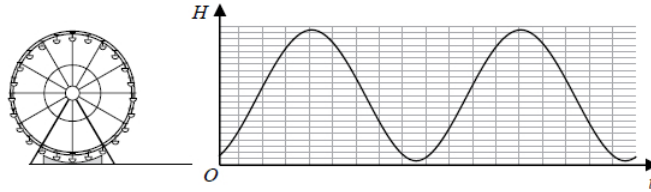

Figure 3

The height above the ground, H metres, of a passenger on a Ferris wheel t minutes after the wheel starts turning, is modelled by the equation

$$H = \alpha - 10 \cos (80 t)^{\circ} + 3 \sin (80 t)^{\circ}$$

where α is a constant.

Figure 3 shows the graph of H against t for two complete cycles of the wheel.

Given that the initial height of the passenger above the ground is 1 metre,

- (b) (i) find a complete equation for the model,
(ii) hence find the maximum height of the passenger above the ground.

(2)

- (c) Find the time taken, to the nearest second, for the passenger to reach the maximum height on the second cycle.

(Solutions based entirely on graphical or numerical methods are not acceptable.)

(3)

It is decided that, to increase profits, the speed of the wheel is to be increased.

- (d) How would you adapt the equation of the model to reflect this increase in speed?

(1)

(Total for question = 9 marks)

(Q13 9MA0/02, Specimen papers)

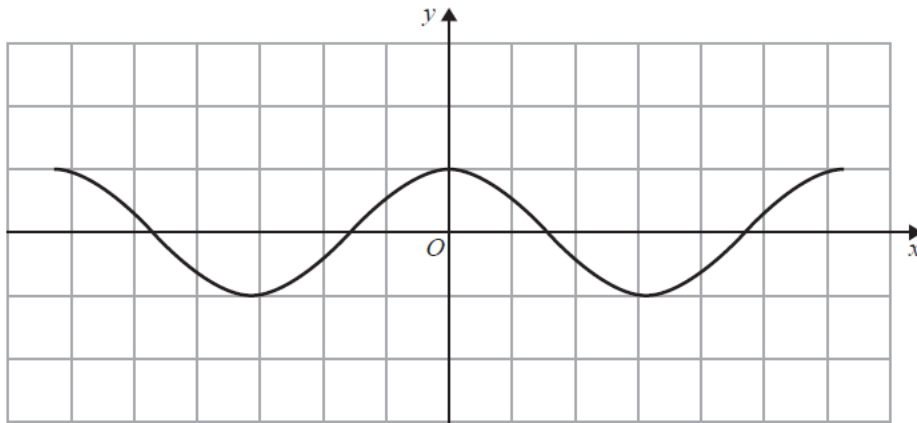

Diagram 1

.....

.....

.....

.....

.....

.....

.....

.....

.....

.....

.....

.....

.....

.....

.....

.....

.....

.....

.....

.....

.....

(Total for question = 5 marks)

(Q02 9MA0/01, June 2019)

Q16.

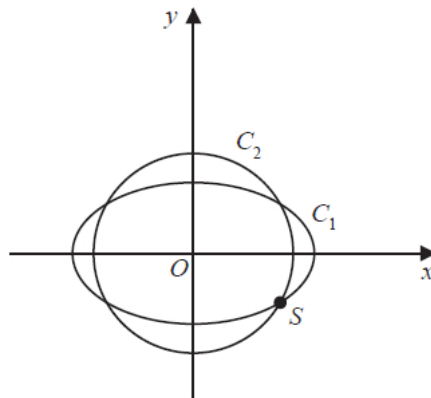

Figure 2

The curve C_1 with parametric equations

$$x = 10 \cos t, \quad y = 4\sqrt{2} \sin t, \quad 0 \leq t < 2\pi$$

meets the circle C_2 with equation

$$x^2 + y^2 = 66$$

at four distinct points as shown in Figure 2.

Given that one of these points, S , lies in the 4th quadrant, find the Cartesian coordinates of S .

(Total for question = 6 marks)

(Q04 9MA0/02, June 2019)

Q17.

(a) Prove that

$$1 - \cos 2\theta \equiv \tan \theta \sin 2\theta, \quad \theta \neq \frac{(2n+1)\pi}{2}, \quad n \in \mathbb{Z}$$

(b) Hence solve, for $-\frac{\pi}{2} < x < \frac{\pi}{2}$, the equation

$$(\sec^2 x - 5)(1 - \cos 2x) = 3 \tan^2 x \sin 2x$$

Give any non-exact answer to 3 decimal places where appropriate.

(6)

(Total for question = 9 marks)

(Q12 9MA0/02, June 2018)

Q18.

In this question you must show all stages of your working.

Solutions relying entirely on calculator technology are not acceptable.

(a) Given that

$$2 \sin (x - 60^\circ) = \cos (x - 30^\circ)$$

show that

$$\tan x = 3\sqrt{3}$$

(b) Hence or otherwise solve, for $0 \leq \theta < 180^\circ$

$$2 \sin 2\theta = \cos (2\theta + 30^\circ)$$

giving your answers to one decimal place.

(4)

(Total for question = 8 marks)

(Q14 9MA0/01, June 2022)

Q19.

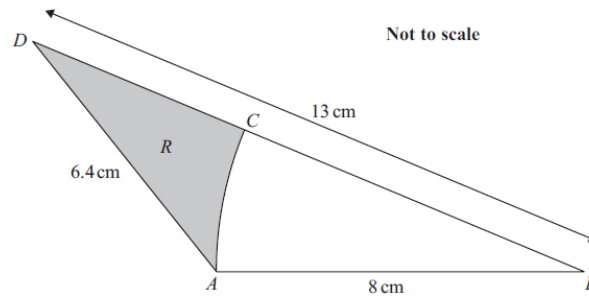

Figure 1

The shape $ABCD$, shown in Figure 1, consists of a triangle ABD containing a sector ABC of a circle with centre B .

Given that

- $AD = 6.4$ cm
- $BD = 13$ cm
- $BA = BC = 8$ cm

(a) show that angle $ABC = 0.394$ radians to 3 significant figures.

(2)

The region R , shown shaded in Figure 1, is bounded by the line CD , the line DA and the arc AC .

(b) Find the area of R , giving the answer in cm^2 to 3 significant figures.

You must make your method clear.

(3)

(Total for question = 5 marks)

(Q04 9MA0/02, June 2025)

Q20.

Given that θ is small and measured in radians, use the small angle approximations to show that

$$4 \sin \frac{\theta}{2} + 3 \cos^2 \theta \approx a + b\theta + c\theta^2$$

where a , b and c are integers to be found.

(Total for question = 3 marks)

(Q04 9MA0/02, Oct 2021)

Q21.

Given that θ is small and in radians, use the small angle approximations to find an approximate numerical value of

$$\frac{\theta \tan 2\theta}{1 - \cos 3\theta}$$

(Total for question = 3 marks)

(Q05 9MA0/02, June 2024)

Q22.

In this question you must show detailed reasoning.

(a) Given that x is small and in radians, use the small angle approximation for $\cos\theta$ to show that

$$1 - \cos^2(2x) \approx 4x^2 - 4x^4$$

(2)

(b) Given that x is small and in radians, use

- the answer to part (a)
 - the small angle approximations for $\sin\theta$ and $\tan\theta$
- to show that

$$\frac{1 - \cos^2(2x)}{\sin\left(\frac{x}{3}\right)\tan\left(\frac{x}{2}\right)} \approx a + bx^2$$

where a and b are constants to be found.

(2)

(c) Hence, given that x is **very** small, deduce an approximate value for

$$\frac{1 - \cos^2(2x)}{\sin\left(\frac{x}{3}\right)\tan\left(\frac{x}{2}\right)}$$

giving a reason for your answer.

(2)

(Total for question = 6 marks)

(Q06 9MA0/02, June 2025)

Q23.

In this question you must show all stages of your working.

Solutions relying entirely on calculator technology are not acceptable.

(a) Show that

$$\operatorname{cosec} \theta - \sin \theta \equiv \cos \theta \cot \theta \quad \theta \neq (180n)^\circ \quad n \in \mathbb{Z}$$

(b) Hence, or otherwise, solve for $0 < x < 180^\circ$

$$\operatorname{cosec} x - \sin x = \cos x \cot (3x - 50^\circ)$$

(5)

(Total for question = 8 marks)

(Q12 9MA0/01, Oct 2020)

Q24.

(a) Solve, for $-180^\circ \leq x < 180^\circ$, the equation

$$3 \sin^2 x + \sin x + 8 = 9 \cos^2 x$$

giving your answers to 2 decimal places.

(6)

(b) Hence find the smallest positive solution of the equation

$$3 \sin^2(2\theta - 30^\circ) + \sin(2\theta - 30^\circ) + 8 = 9 \cos^2(2\theta - 30^\circ)$$

giving your answer to 2 decimal places.

(2)

(Total for question = 8 marks)

(Q12 9MA0/02, Specimen papers)

Q25.

(i) Solve, for $0 \leq x < \frac{\pi}{2}$, the equation

$$4 \sin x = \sec x$$

(ii) Solve, for $0 \leq \theta < 360^\circ$, the equation

$$5 \sin \theta - 5 \cos \theta = 2$$

giving your answers to one decimal place.

(Solutions based entirely on graphical or numerical methods are not acceptable.)

(5)

(Total for question = 9 marks)

(Q07 9MA0/02, June 2018)

Q26.

(a) Prove

$$\frac{\cos 3\theta}{\sin \theta} + \frac{\sin 3\theta}{\cos \theta} \equiv 2 \cot 2\theta \quad \theta \neq (90n)^\circ, n \in \mathbb{Z}$$

(4)

(b) Hence solve, for $90^\circ < \theta < 180^\circ$, the equation

$$\frac{\cos 3\theta}{\sin \theta} + \frac{\sin 3\theta}{\cos \theta} = 4$$

giving any solutions to one decimal place.

(3)

(Total for question = 7 marks)

(Q12 9MA0/02, June 2019)

Q27.

In this question you should show all stages of your working.

Solutions relying entirely on calculator technology are not acceptable.

(a) Given that $1 + \cos 2\theta + \sin 2\theta \neq 0$ prove that

$$\frac{1 - \cos 2\theta + \sin 2\theta}{1 + \cos 2\theta + \sin 2\theta} \equiv \tan \theta$$

(4)

(b) Hence solve, for $0 < x < 180^\circ$

$$\frac{1 - \cos 4x + \sin 4x}{1 + \cos 4x + \sin 4x} = 3 \sin 2x$$

giving your answers to one decimal place where appropriate.

(4)

(Total for question = 8 marks)

(Q10 9MA0/01, Oct 2021)

Q28.

In this question you must show all stages of your working.

Solutions relying entirely on calculator technology are not acceptable.

(a) Show that the equation

$$2 \tan \theta (8 \cos \theta + 23 \sin^2 \theta) = 8 \sin 2\theta (1 + \tan^2 \theta)$$

may be written as

$$\sin 2\theta (A \cos^2 \theta + B \cos \theta + C) = 0$$

where A, B and C are constants to be found.

(b) Hence, solve for $360^\circ \leq x \leq 540^\circ$

$$2 \tan x (8 \cos x + 23 \sin^2 x) = 8 \sin 2x (1 + \tan^2 x) \quad x \in \mathbb{R} \quad x \neq 450^\circ$$

(4)

(Total for question = 7 marks)

(Q14 9MA0/02, June 2023)

Q29.

In this question you must show all stages of your working.

Solutions relying entirely on calculator technology are not acceptable.

(a) Prove that

$$\frac{1}{\operatorname{cosec} \theta - 1} + \frac{1}{\operatorname{cosec} \theta + 1} \equiv 2 \tan \theta \sec \theta \quad \theta \neq (90n)^\circ, n \in \mathbb{Z}$$

(b) Hence solve, for $0 < x < 90^\circ$, the equation

$$\frac{1}{\operatorname{cosec} 2x - 1} + \frac{1}{\operatorname{cosec} 2x + 1} = \cot 2x \sec 2x$$

Give each answer, in degrees, to one decimal place.

(4)

(Total for question = 7 marks)

(Q08 9MA0/02, June 2024)

Q30.

In this question you must show all stages of your working.

Solutions relying on calculator technology are not acceptable.

(a) Show that

$$\sin(x + 30^\circ) + \sqrt{3} \cos(x + 30^\circ) \equiv 2\cos x$$

(b) Hence solve, for $0 \leq \theta < 180^\circ$

$$\sin(\theta + 30^\circ) + \sqrt{3} \cos(\theta + 30^\circ) = 3\sin 2\theta$$

giving your answers to one decimal place, where appropriate.

(4)

(Total for question = 7 marks)

(Q14 9MA0/01, June 2025)

Q31.

Given that for all values of k , where $0 < |k| < 1$, the equation

$$\sin(nx) = k \quad n \in \mathbb{N}$$

has exactly 6 solutions in the interval $0 \leq x < 2\pi$

(i) deduce the value of n

(1)

(ii) deduce the number of solutions of the equation

$$\sin^2(nx) = k^2$$

in the interval $0 \leq x < 5\pi$, justifying your answer.

(2)

(Total for question = 3 marks)

(Q13 9MA0/02, June 2025)

Q32.

- (a) Express $2\cos \theta - \sin \theta$ in the form $R \cos (\theta + \alpha)$, where $R > 0$ and $0 < \alpha < \frac{\pi}{2}$.
Give the exact value of R and the value of α in radians to 3 decimal places.

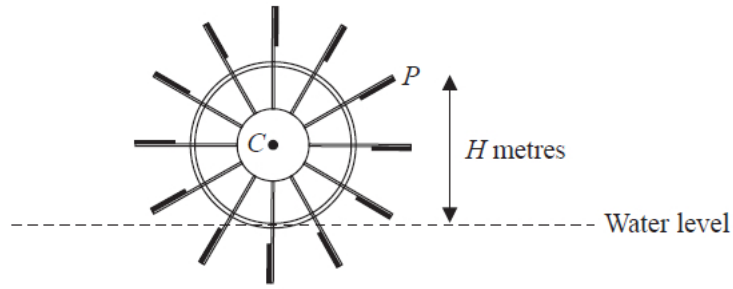

Figure 6

Figure 6 shows the cross-section of a water wheel.

The wheel is free to rotate about a fixed axis through the point C .

The point P is at the end of one of the paddles of the wheel, as shown in Figure 6.

The water level is assumed to be horizontal and of constant height.

The vertical height, H metres, of P above the water level is modelled by the equation

$$H = 3 + 4 \cos (0.5t) - 2 \sin (0.5t)$$

where t is the time in seconds after the wheel starts rotating.

Using the model, find

- (b) (i) the maximum height of P above the water level,
(ii) the value of t when this maximum height first occurs, giving your answer to one decimal place.

In a single revolution of the wheel, P is below the water level for a total of T seconds.

According to the model,

(c) find the value of T giving your answer to 3 significant figures.

(Solutions based entirely on calculator technology are not acceptable.)

(4)

In reality, the water level may not be of constant height.

(d) Explain how the equation of the model should be refined to take this into account.

(1)

(Total for question = 11 marks)

(Q15 9MA0/02, Oct 2021)

Q33.

- (a) Express $2 \cos \theta + 8 \sin \theta$ in the form $R \cos(\theta - \alpha)$, where R and α are constants, $R > 0$ and $0 < \alpha < \frac{\pi}{2}$.
Give the exact value of R and give the value of α in radians to 3 decimal places.

(3)

The first three terms of an arithmetic sequence are

$$\cos x \quad \cos x + \sin x \quad \cos x + 2 \sin x \quad x \neq n\pi$$

Given that S_9 represents the sum of the first 9 terms of this sequence as x varies,

- (b) (i) find the exact maximum value of S_9
(ii) deduce the smallest positive value of x at which this maximum value of S_9 occurs.

(3)

(Total for question = 6 marks)

(Q08 9MA0/02, June 2023)

Q34.

(a) Solve, for $-180^\circ \leq \theta \leq 180^\circ$, the equation

$$5 \sin 2\theta = 9 \tan \theta$$

giving your answers, where necessary, to one decimal place.

[Solutions based entirely on graphical or numerical methods are not acceptable.]

(6)

(b) Deduce the smallest positive solution to the equation

$$5 \sin (2x - 50^\circ) = 9 \tan (x - 25^\circ)$$

(2)

(Total for question = 8 marks)

(Q06 9MA0/01, June 2019)

Q35.

(a) Express $140 \cos \theta - 480 \sin \theta$ in the form $K \cos(\theta + \alpha)$

where $K > 0$ and $0 < \alpha < 90^\circ$

State the value of K and give the value of α , in degrees, to 2 decimal places.

A scientist studies the number of rabbits and the number of foxes in a wood for one year.

The number of rabbits, R , is modelled by the equation

$$R = A + 140 \cos(30t)^\circ - 480 \sin(30t)^\circ$$

where t months is the time after the start of the year and A is a constant.

Given that, during the year, the maximum number of rabbits in the wood is 1500

(b) (i) find a complete equation for this model.

(ii) Hence write down the minimum number of rabbits in the wood during the year according to the model.

(2)

The actual number of rabbits in the wood is at its minimum value in the middle of April.

(c) Use this information to comment on the model for the number of rabbits.

(2)

The number of foxes, F , in the wood during the same year is modelled by the equation

$$F = 100 + 70 \sin(30t + 70)^\circ$$

The number of foxes is at its minimum value after T months.

(d) Find, according to the models, the number of **rabbits** in the wood at time T months.

(4)

(Total for question = 11 marks)

(Q12 9MA0/01, June 2024)

Q36.

(a) Express $\sin x + 2 \cos x$ in the form $R \sin(x + \alpha)$ where R and α are constants, $R > 0$

and $0 < \alpha < \frac{\pi}{2}$

Give the exact value of R and give the value of α in radians to 3 decimal places.

The temperature, θ °C , inside a room on a given day is modelled by the equation

$$\theta = 5 + \sin\left(\frac{\pi t}{12} - 3\right) + 2 \cos\left(\frac{\pi t}{12} - 3\right) \quad 0 \leq t < 24$$

where t is the number of hours after midnight.

Using the equation of the model and your answer to part (a),

(b) deduce the maximum temperature of the room during this day,

(1)

(c) find the time of day when the maximum temperature occurs, giving your answer to the nearest minute.

(3)

(Total for question = 7 marks)

(Q06 9MA0/01, Oct 2020)

Q37.

In this question you must show all stages of your working.

Solutions relying entirely on calculator technology are not acceptable.

(a) Show that

$$\cos 3A \equiv 4\cos^3 A - 3\cos A$$

(4)

(b) Hence solve, for $-90^\circ \leq x \leq 180^\circ$, the equation

$$1 - \cos 3x = \sin^2 x$$

(4)

(Total for question = 8 marks)

(Q10 9MA0/02, Oct 2020)

Q38.

A curve C has parametric equations

$$x = 3 + 2 \sin t, \quad y = 4 + 2 \cos 2t, \quad 0 \leq t < 2\pi$$

(a) Show that all points on C satisfy $y = 6 - (x - 3)^2$

(2)

(b) (i) Sketch the curve C .

(ii) Explain briefly why C does not include all points of $y = 6 - (x - 3)^2$, $x \in \mathbb{R}$

(3)

The line with equation $x + y = k$, where k is a constant, intersects C at two distinct points.

(c) State the range of values of k , writing your answer in set notation.

(5)

(Total for question = 10 marks)

(Q14 9MA0/01, June 2018)

Q39.

Given that

$$y = \frac{3\sin\theta}{2\sin\theta + 2\cos\theta} \quad -\frac{\pi}{4} < \theta < \frac{3\pi}{4}$$

show that

$$\frac{dy}{d\theta} = \frac{A}{1 + \sin 2\theta} \quad -\frac{\pi}{4} < \theta < \frac{3\pi}{4}$$

where A is a rational constant to be found.

(5)

(Total for question = 5 marks)

(Q05 9MA0/01, June 2018)

Q40.

In this question you must show all stages of your working.

Solutions relying entirely on calculator technology are not acceptable.

The curve C has equation $y = f(x)$ where $x \in \mathbb{R}$

Given that

- $f'(x) = \frac{1}{2x^2} \cos x$
- the curve has a stationary point with x coordinate α
- α is small

(a) use the small angle approximation for $\cos x$ to estimate the value of α to 3 decimal places.

(3)

The point $P(0, 3)$ lies on C

(b) Find the equation of the tangent to the curve at P , giving your answer in the form $y = mx + c$, where m and c are constants to be found.

(2)

(Total for question = 5 marks)

(Q04 9MA0/01, June 2023)